

12-4 Volumes of Prisms and Cylinders

Find the volume of each prism.

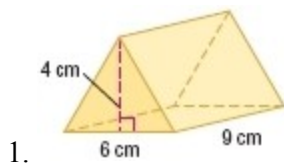

SOLUTION:

The volume V of a prism is $V = Bh$, where B is the area of a base and h is the height of the prism.

$$\begin{aligned}V &= Bh \\ &= \frac{1}{2}(6)(4) \cdot 9 \\ &= 12 \cdot 9 \\ &= 108\end{aligned}$$

The volume is 108 cm^3 .

ANSWER:

$$108 \text{ cm}^3$$

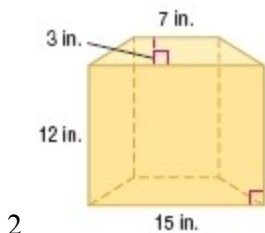

SOLUTION:

The volume V of a prism is $V = Bh$, where B is the area of a base and h is the height of the prism.

$$\begin{aligned}V &= Bh \\ &= \frac{1}{2}(7 + 15)(3) \cdot 12 \\ &= 33 \cdot 12 \\ &= 396\end{aligned}$$

ANSWER:

$$396 \text{ in}^3$$

12-4 Volumes of Prisms and Cylinders

3. the oblique rectangular prism shown at the right

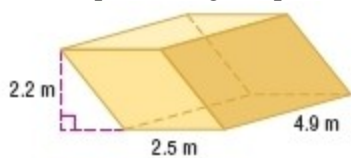

SOLUTION:

If two solids have the same height h and the same cross-sectional area B at every level, then they have the same volume. So, the volume of a right prism and an oblique one of the same height and cross sectional area are same.

$$\begin{aligned}V &= Bh \\ &= (2.5)(2.2) \cdot 4.9 \\ &= 5.5 \cdot 4.9 \\ &= 26.95\end{aligned}$$

ANSWER:

$$26.95 \text{ m}^3$$

4. an oblique pentagonal prism with a base area of 42 square centimeters and a height of 5.2 centimeters

SOLUTION:

If two solids have the same height h and the same cross-sectional area B at every level, then they have the same volume. So, the volume of a right prism and an oblique one of the same height and cross sectional area are same.

$$\begin{aligned}V &= Bh \\ &= 42 \cdot 5.2 \\ &= 218.4\end{aligned}$$

ANSWER:

$$218.4 \text{ cm}^3$$

12-4 Volumes of Prisms and Cylinders

Find the volume of each cylinder. Round to the nearest tenth.

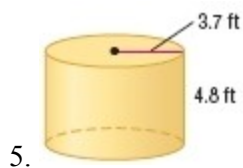

SOLUTION:

$$\begin{aligned}V &= Bh \\&= \pi r^2 \cdot h \\&= \pi(3.7)^2(4.8) \\&\approx 206.4\end{aligned}$$

ANSWER:

$$206.4 \text{ ft}^3$$

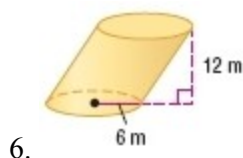

SOLUTION:

If two solids have the same height h and the same cross-sectional area B at every level, then they have the same volume. So, the volume of a right cylinder and an oblique one of the same height and cross sectional area are same.

$$\begin{aligned}V &= Bh \\&= \pi r^2 \cdot h \\&= \pi(6)^2(12) \\&\approx 1357.2\end{aligned}$$

ANSWER:

$$1357.2 \text{ m}^3$$

7. a cylinder with a diameter of 16 centimeters and a height of 5.1 centimeters

SOLUTION:

$$\begin{aligned}V &= Bh \\&= \pi r^2 \cdot h \\&= \pi(8)^2(5.1) \\&\approx 1025.4\end{aligned}$$

ANSWER:

$$1025.4 \text{ cm}^3$$

12-4 Volumes of Prisms and Cylinders

8. a cylinder with a radius of 4.2 inches and a height of 7.4 inches

SOLUTION:

$$\begin{aligned}V &= Bh \\&= \pi r^2 \cdot h \\&= \pi(4.2)^2(7.4) \\&\approx 410.1\end{aligned}$$

ANSWER:

$$410.1 \text{ in}^3$$

9. **MULTIPLE CHOICE** A rectangular lap pool measures 80 feet long by 20 feet wide. If it needs to be filled to four feet deep and each cubic foot holds 7.5 gallons, how many gallons will it take to fill the lap pool?

- A** 4000
B 6400
C 30,000
D 48,000

SOLUTION:

$$\begin{aligned}V &= Bh \\&= 20(80) \cdot 4 \\&= 6400\end{aligned}$$

Each cubic foot holds 7.5 gallons of water. So, the amount of water required to fill the pool is $6400(7.5) = 48,000$.

Therefore, the correct choice is D.

ANSWER:

D

CCSS SENSE-MAKING Find the volume of each prism.

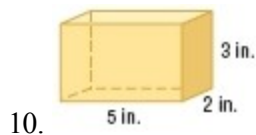

SOLUTION:

The base is a rectangle of length 3 in. and width 2 in. The height of the prism is 5 in.

$$\begin{aligned}V &= lwh \\&= 2 \cdot 3 \cdot 5 \\&= 30\end{aligned}$$

ANSWER:

$$30 \text{ in}^3$$

12-4 Volumes of Prisms and Cylinders

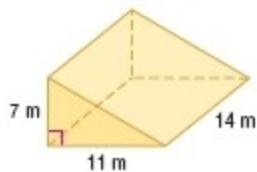

11.

SOLUTION:

The base is a triangle with a base length of 11 m and the corresponding height of 7 m. The height of the prism is 14 m.

$$\begin{aligned} V &= \frac{1}{2}(7 \cdot 11 \cdot 14) \\ &= 539 \end{aligned}$$

ANSWER:

$$539 \text{ m}^3$$

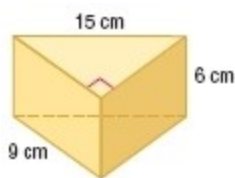

12.

SOLUTION:

The base is a right triangle with a leg length of 9 cm and the hypotenuse of length 15 cm.

Use the Pythagorean Theorem to find the height of the base.

$$\begin{aligned} a^2 + b^2 &= c^2 \\ a^2 + 9^2 &= 15^2 \\ a^2 &= 15^2 - 9^2 \\ a &= \sqrt{144} \\ a &= 12 \end{aligned}$$

The height of the prism is 6 cm.

$$\begin{aligned} V &= \frac{1}{2} \cdot 9 \cdot 12 \cdot 6 \\ &= 324 \end{aligned}$$

ANSWER:

$$324 \text{ cm}^3$$

12-4 Volumes of Prisms and Cylinders

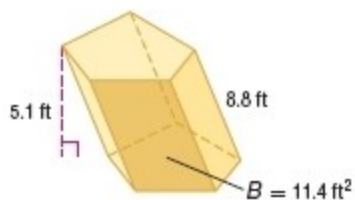

13.

SOLUTION:

If two solids have the same height h and the same cross-sectional area B at every level, then they have the same volume. So, the volume of a right prism and an oblique one of the same height and cross sectional area are same.

The volume V of a prism is $V = Bh$, where B is the area of a base and h is the height of the prism.

$B = 11.4 \text{ ft}^2$ and $h = 5.1 \text{ ft}$. Therefore, the volume is $(11.4)(5.1) = 58.14 \text{ ft}^3$.

ANSWER:

58.14 ft^3

14. an oblique hexagonal prism with a height of 15 centimeters and with a base area of 136 square centimeters

SOLUTION:

If two solids have the same height h and the same cross-sectional area B at every level, then they have the same volume. So, the volume of a right prism and an oblique one of the same height and cross sectional area are same.

$$\begin{aligned} V &= Bh \\ &= (136)(15) \\ &= 2040 \end{aligned}$$

ANSWER:

2040 cm^3

15. a square prism with a base edge of 9.5 inches and a height of 17 inches

SOLUTION:

If two solids have the same height h and the same cross-sectional area B at every level, then they have the same volume. So, the volume of a right prism and an oblique one of the same height and cross sectional area are same.

$$\begin{aligned} V &= Bh \\ &= (9.5)^2 \cdot 17 \\ &= 1534.25 \end{aligned}$$

ANSWER:

1534.25 in^3

12-4 Volumes of Prisms and Cylinders

CCSS SENSE-MAKING Find the volume of each cylinder. Round to the nearest tenth.

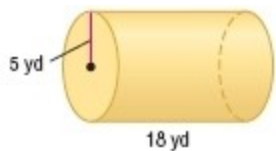

16.

SOLUTION:

$r = 5$ yd and $h = 18$ yd

$$\begin{aligned} V &= \pi r^2 h \\ &= \pi(5)^2 \cdot 18 \\ &\approx 1413.7 \end{aligned}$$

ANSWER:

1413.7 yd³

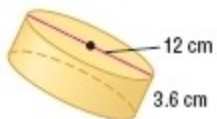

17.

SOLUTION:

$r = 6$ cm and $h = 3.6$ cm.

$$\begin{aligned} V &= \pi r^2 h \\ &= \pi(6)^2 \cdot 3.6 \\ &\approx 407.2 \end{aligned}$$

ANSWER:

407.2 cm³

12-4 Volumes of Prisms and Cylinders

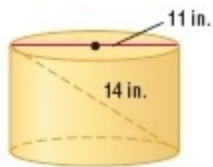

18.

SOLUTION:

$$r = 5.5 \text{ in.}$$

Use the Pythagorean Theorem to find the height of the cylinder.

$$a^2 + b^2 = c^2$$

$$a^2 + 11^2 = 14^2$$

$$a^2 = 14^2 - 11^2$$

$$a = \sqrt{14^2 - 11^2}$$

$$a = \sqrt{196 - 121}$$

$$a = \sqrt{75}$$

Now you can find the volume.

$$V = \pi r^2 h$$

$$= \pi(5.5)^2 \cdot \sqrt{75}$$

$$\approx 823.0$$

ANSWER:

$$823.0 \text{ in}^3$$

12-4 Volumes of Prisms and Cylinders

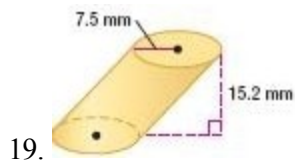

SOLUTION:

If two solids have the same height h and the same cross-sectional area B at every level, then they have the same volume. So, the volume of a right prism and an oblique one of the same height and cross sectional area are same.

$$r = 7.5 \text{ mm and } h = 15.2 \text{ mm.}$$

$$\begin{aligned} V &= \pi r^2 h \\ &= \pi (7.5)^2 \cdot 15.2 \\ &\approx 2686.1 \end{aligned}$$

ANSWER:

$$2686.1 \text{ mm}^3$$

20. **PLANTER** A planter is in the shape of a rectangular prism 18 inches long, $14\frac{1}{2}$ inches deep, and 12 inches high.

What is the volume of potting soil in the planter if the planter is filled to $1\frac{1}{2}$ inches below the top?

SOLUTION:

The planter is to be filled $1\frac{1}{2}$ inches below the top, so $h = 12 - 1\frac{1}{2} = 10\frac{1}{2}$ in.

$$\begin{aligned} V &= Bh \\ &= (18)(14.5) \cdot 10.5 \\ &= 2740.5 \end{aligned}$$

ANSWER:

$$2740.5 \text{ in}^3$$

12-4 Volumes of Prisms and Cylinders

21. **SHIPPING** A box 18 centimeters by 9 centimeters by 15 centimeters is being used to ship two cylindrical candles. Each candle has a diameter of 9 centimeters and a height of 15 centimeters, as shown at the right. What is the volume of the empty space in the box?

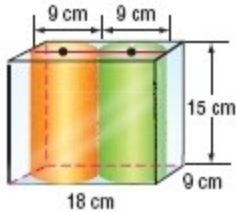

SOLUTION:

The volume of the empty space is the difference of volumes of the rectangular prism and the cylinders.

$$\begin{aligned} V &= V(\text{prism}) - V(\text{cylinders}) \\ &= 9(18)(15) - 2\left[\pi(4.5)^2(15)\right] \\ &= 2430 - 607.5\pi \\ &\approx 521.5 \end{aligned}$$

ANSWER:

$$521.5 \text{ cm}^3$$

22. **SANDCASTLES** In a sandcastle competition, contestants are allowed to use only water, shovels, and 10 cubic feet of sand. To transport the correct amount of sand, they want to create cylinders that are 2 feet tall to hold enough sand for one contestant. What should the diameter of the cylinders be?

SOLUTION:

$V = 10 \text{ ft}^3$ and $h = 2 \text{ ft}$ Use the formula to find r .

$$\begin{aligned} \pi r^2 h &= V \\ \pi r^2 (2) &= 10 \\ r^2 &= \frac{10}{2\pi} \\ &\approx 1.59 \\ r &\approx 1.26 \end{aligned}$$

Therefore, the diameter of the cylinders should be about 2.52 ft.

ANSWER:

$$2.52 \text{ ft}$$

12-4 Volumes of Prisms and Cylinders

Find the volume of the solid formed by each net.

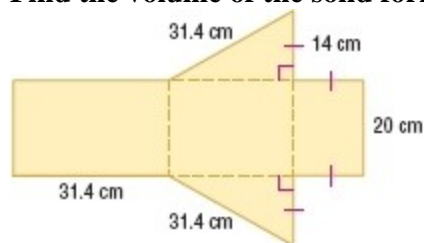

23.

SOLUTION:

The middle piece of the net is the front of the solid. The top and bottom pieces are the bases and the pieces on the ends are the side faces. This is a triangular prism.

One leg of the base 14 cm and the hypotenuse 31.4 cm. Use the Pythagorean Theorem to find the height of the base.

$$h = \sqrt{(31.4)^2 - (14)^2} = \sqrt{789.96} \approx 28.1$$

The height of the prism is 20 cm.

The volume V of a prism is $V = Bh$, where B is the area of the base, h is the height of the prism.

$$\begin{aligned} V &= Bh \\ &= \frac{1}{2}(14)(28.1)(20) \\ &\approx 3934.9 \end{aligned}$$

ANSWER:

$$3934.9 \text{ cm}^3$$

12-4 Volumes of Prisms and Cylinders

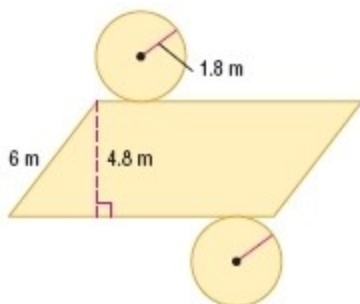

24.

SOLUTION:

The circular bases at the top and bottom of the net indicate that this is a cylinder. If the middle piece were a rectangle, then the prism would be right. However, since the middle piece is a parallelogram, it is oblique.

The radius is 1.8 m, the height is 4.8 m, and the slant height is 6 m.

If two solids have the same height h and the same cross-sectional area B at every level, then they have the same volume. So, the volume of a right prism and an oblique one of the same height and cross sectional area are same.

$$\begin{aligned}V &= Bh \\ &= \pi r^2 h \\ &= \pi(1.8)^2(4.8) \\ &\approx 48.9\end{aligned}$$

ANSWER:

$$48.9 \text{ m}^3$$

12-4 Volumes of Prisms and Cylinders

25. **FOOD** A cylindrical can of baked potato chips has a height of 27 centimeters and a radius of 4 centimeters. A new can is advertised as being 30% larger than the regular can. If both cans have the same radius, what is the height of the larger can?



SOLUTION:

The volume of the smaller can is $\pi(4)^2(27) = 432\pi \text{ cm}^3$.

The volume of the new can is 130% of the smaller can, with the same radius.

$$V = \pi r^2 h$$

$$130\% \text{ of } 432\pi = \pi(4)^2 h$$

$$1.3 \cdot 432\pi = 16\pi h$$

$$\frac{1.3 \cdot 432\pi}{16\pi} = h$$

$$35.1 = h$$

The height of the new can will be 35.1 cm.

ANSWER:

35.1 cm

26. **CHANGING DIMENSIONS** A cylinder has a radius of 5 centimeters and a height of 8 centimeters. Describe how each change affects the volume of the cylinder.
- The height is tripled.
 - The radius is tripled.
 - Both the radius and the height are tripled.
 - The dimensions are exchanged.

SOLUTION:

$$V = Bh$$

$$= \pi r^2 \cdot h$$

$$= \pi(5)^2(8)$$

$$= 200\pi$$

a.

When the height is tripled, $h = 3h$.

$$V = Bh$$

$$= \pi r^2 \cdot 3h$$

$$= \pi(5)^2(3 \cdot 8)$$

$$= 600\pi$$

When the height is tripled, the volume is multiplied by 3.

12-4 Volumes of Prisms and Cylinders

b. When the radius is tripled, $r = 3r$.

$$\begin{aligned}V &= Bh \\&= \pi(3r)^2 \cdot h \\&= \pi(3 \cdot 5)^2(8) \\&= \pi(225)(8) \\&= 1800\pi\end{aligned}$$

So, when the radius is tripled, the volume is multiplied by 9.

c. When the height and the radius are tripled, $r = 3r$ and $h = 3h$.

$$\begin{aligned}V &= Bh \\&= \pi(3r)^2 \cdot 3h \\&= \pi(3 \cdot 5)^2(3 \cdot 8) \\&= \pi(225)(24) \\&= 5400\pi\end{aligned}$$

When the height and the radius are tripled, the volume is multiplied by 27.

d. When the dimensions are exchanged, $r = 8$ and $h = 5$ cm.

$$\begin{aligned}V &= Bh \\&= \pi r^2 \cdot h \\&= \pi(8)^2(5) \\&= 320\pi\end{aligned}$$

Compare to the original volume.

$$\frac{320\pi}{200\pi} = \frac{8}{5}$$

The volume is multiplied by $\frac{8}{5}$.

ANSWER:

- a. The volume is multiplied by 3.
- b. The volume is multiplied by 3^2 or 9.
- c. The volume is multiplied by 3^3 or 27.
- d. The volume is multiplied by $\frac{8}{5}$.

12-4 Volumes of Prisms and Cylinders

27. **SOIL** A soil scientist wants to determine the bulk density of a potting soil to assess how well a specific plant will grow in it. The density of the soil sample is the ratio of its weight to its volume.

- a.** If the weight of the container with the soil is 20 pounds and the weight of the container alone is 5 pounds, what is the soil's bulk density? **b.** Assuming that all other factors are favorable, how well should a plant grow in this soil if a bulk density of 0.018 pound per square inch is desirable for root growth? Explain.
c. If a bag of this soil holds 2.5 cubic feet, what is its weight in pounds?

SOLUTION:



- a.** First calculate the volume of soil in the pot. Then divide the weight of the soil by the volume.

$$\begin{aligned}V &= \pi r^2 h \\&= \pi \cdot 10^2 \cdot 25 \\&= 2500\pi \\&\approx 7854 \text{ in}^3\end{aligned}$$

The weight of the soil is the weight of the pot with soil minus the weight of the pot.
 $W = 20 - 5 = 15 \text{ lbs.}$

The soil density is thus:

$$\begin{aligned}D &= \frac{15}{2500\pi} \\&= 0.0019 \text{ lb / in}^3\end{aligned}$$

- b.** 0.0018 lb/in³ is close to 0.0019 lb/in³ so the plant should grow fairly well.

c.

$$2.5 \text{ ft}^3 \left(\frac{12 \text{ in}}{\text{ft}} \right)^3 = 4320 \text{ in}^3$$

$$\begin{aligned}W &= V \cdot D \\&= 4320 \cdot 0.0019 \\&= 8.3 \text{ lb}\end{aligned}$$

ANSWER:

a. 0.0019 lb / in³

b. The plant should grow well in this soil since the bulk density of 0.0019 lb / in³ is close to the desired bulk density of 0.0018 lb / in³.

c. 8.3 lb

12-4 Volumes of Prisms and Cylinders

Find the volume of each composite solid. Round to the nearest tenth if necessary.

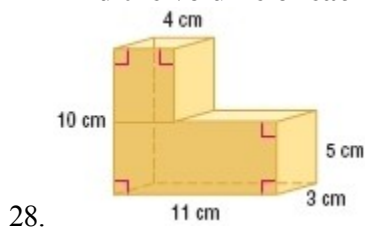

SOLUTION:

The solid is a combination of two rectangular prisms. The base of one rectangular prism is 5 cm by 3 cm and the height is 11 cm. The base of the other prism is 4 cm by 3 cm and the height is 5 cm.

$$\begin{aligned}V &= V_1 + V_2 \\ &= 3 \cdot 5 \cdot 11 + (3 \cdot 5 \cdot 4) \\ &= 165 + 60 \\ &= 225\end{aligned}$$

ANSWER:

$$225 \text{ cm}^3$$

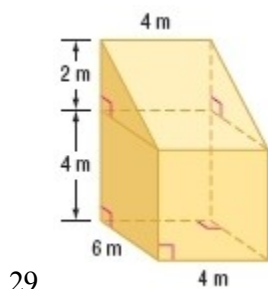

SOLUTION:

The solid is a combination of a rectangular prism and a right triangular prism. The total volume of the solid is the sum of the volumes of the two rectangular prisms.

$$\begin{aligned}V &= V_1 + V_2 \\ &= 4 \cdot 6 \cdot 4 + \frac{1}{2}(6 \cdot 2 \cdot 4) \\ &= 96 + 24 \\ &= 120\end{aligned}$$

ANSWER:

$$120 \text{ m}^3$$

12-4 Volumes of Prisms and Cylinders

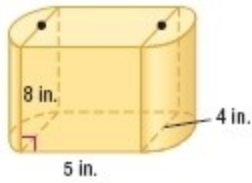

30.

SOLUTION:

The solid is a combination of a rectangular prism and two half cylinders.

$$\begin{aligned} V &= V_1 + V_2 \\ &= 4 \cdot 5 \cdot 8 + 2 \left[\frac{1}{2} \pi (2)^2 (8) \right] \\ &= 160 + 32\pi \\ &\approx 260.5 \end{aligned}$$

ANSWER:

$$260.5 \text{ in}^3$$

31. **MANUFACTURING** A can 12 centimeters tall fits into a rubberized cylindrical holder that is 11.5 centimeters tall, including 1 centimeter for the thickness of the base of the holder. The thickness of the rim of the holder is 1 centimeter. What is the volume of the rubberized material that makes up the holder?



SOLUTION:

The volume of the rubberized material is the difference between the volumes of the container and the space used for the can. The container has a radius of $\frac{6.5}{2} + 1 = 4.25 \text{ cm}$ and a height of 11.5 cm. The empty space used to keep the can has a radius of 3.25 cm and a height of $11.5 - 1 = 10.5 \text{ cm}$. The volume V of a cylinder is $V = \pi r^2 h$, where r is the radius of the base and h is the height of the cylinder.

$$\begin{aligned} V_{\text{rubberized material}} &= \pi r_c^2 h_c - \pi r_e^2 h_e \\ &= \pi (4.25)^2 (11.5) - \pi (3.25)^2 (10.5) \\ &\approx 304.1 \end{aligned}$$

Therefore, the volume of the rubberized material is about 304.1 cm^3 .

ANSWER:

$$304.1 \text{ cm}^3$$

12-4 Volumes of Prisms and Cylinders

Find each measure to the nearest tenth.

32. A cylindrical can has a volume of 363 cubic centimeters. The diameter of the can is 9 centimeters. What is the height?

SOLUTION:

$$V = Bh$$

$$V = \pi r^2 \cdot h$$

$$363 = \pi(4.5)^2 h$$

$$\frac{363}{\pi(4.5)^2} = h$$

$$5.7 \approx h$$

ANSWER:

5.7 cm

12-4 Volumes of Prisms and Cylinders

33. A cylinder has a surface area of 144π square inches and a height of 6 inches. What is the volume?

SOLUTION:

Use the surface area formula to solve for r .

$$S = 2\pi rh + 2B$$

$$S = 2\pi rh + 2\pi r^2$$

$$144\pi = 2\pi r(6) + 2\pi r^2$$

$$144\pi = 12\pi r + 2\pi r^2$$

$$72\pi = 6\pi r + \pi r^2$$

$$72 = 6r + r^2$$

$$0 = r^2 + 6r - 72$$

$$0 = (r + 12)(r - 6)$$

$$r = -12 \text{ or } 6$$

The radius is 6. Find the volume.

$$V = Bh$$

$$= \pi r^2 \cdot h$$

$$= \pi(6)^2(6)$$

$$\approx 678.6$$

ANSWER:

$$678.6 \text{ in}^3$$

12-4 Volumes of Prisms and Cylinders

34. A rectangular prism has a surface area of 432 square inches, a height of 6 inches, and a width of 12 inches. What is the volume?

SOLUTION:

Use the surface area formula to find the length of the base of the prism.

$$S = Ph + 2B$$

$$432 = 2(l + 12)(6) + 2(l)(12)$$

$$432 = 12l + 144 + 24l$$

$$288 = 36l$$

$$8 = l$$

Find the volume.

$$V = Bh$$

$$= lwh$$

$$= (8)(12)(6)$$

$$= 576$$

ANSWER:

$$576 \text{ in}^3$$

35. **ARCHITECTURE** A cylindrical stainless steel column is used to hide a ventilation system in a new building. According to the specifications, the diameter of the column can be between 30 centimeters and 95 centimeters. The height is to be 500 centimeters. What is the difference in volume between the largest and smallest possible column? Round to the nearest tenth cubic centimeter.

SOLUTION:

The volume will be the highest when the diameter is 95 cm and will be the lowest when it is 30 cm. That is when the radii are 47.5 cm and 15 cm respectively.

Find the difference between the volumes.

$$V = V_1 - V_2$$

$$= \pi(47.5)^2 \cdot 500 - [\pi(15)^2 \cdot 500]$$

$$= 1,128,125\pi - 112,500\pi$$

$$= 1,015,625\pi$$

$$\approx 3,190,680.0$$

ANSWER:

$$3,190,680.0 \text{ cm}^3$$

12-4 Volumes of Prisms and Cylinders

36. **CCSS MODELING** The base of a rectangular swimming pool is sloped so one end of the pool is 6 feet deep and the other end is 3 feet deep, as shown in the figure. If the width is 15 feet, find the volume of water it takes to fill the pool.

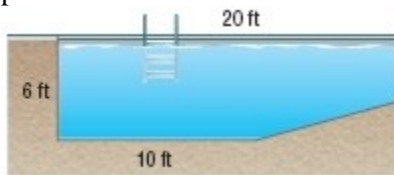

SOLUTION:

The swimming pool is a combination of a rectangular prism and a trapezoidal prism. The base of the rectangular prism is 6 ft by 10 ft and the height is 15 ft. The bases of the trapezoidal prism are 6 ft and 3 ft long and the height of the base is 10 ft. The height of the trapezoidal prism is 15 ft. The total volume of the solid is the sum of the volumes of the two prisms.

$$\begin{aligned}V &= lwh + \left[\frac{1}{2}(b_1 + b_2)h \right]h \\ &= 6(10)(15) + \left[\frac{1}{2}(6 + 3)(10) \right](15) \\ &= 900 + 675 \\ &= 1575\end{aligned}$$

ANSWER:

$$1575 \text{ ft}^3$$

12-4 Volumes of Prisms and Cylinders

37. **CHANGING DIMENSIONS** A soy milk company is planning a promotion in which the volume of soy milk in each container will be increased by 25%. The company wants the base of the container to stay the same. What will be the height of the new containers?



SOLUTION:

Find the volume of the original container.

$$\begin{aligned}V &= Bh \\ &= (2)(4)(9) \\ &= 72\end{aligned}$$

The volume of the new container is 125% of the original container, with the same base dimensions. Use $1.25V$ and B to find h .

$$\begin{aligned}V &= Bh \\ 1.25(72) &= (2)(4)h \\ 90 &= 8h \\ 11.25 &= h\end{aligned}$$

ANSWER:

$$11\frac{1}{4} \text{ in.}$$

38. **DESIGN** Sketch and label (in inches) three different designs for a dry ingredient measuring cup that holds 1 cup. Be sure to include the dimensions in each drawing. (1 cup $\approx 14.4375 \text{ in}^3$)

SOLUTION:

Sample answers:

For any cylindrical container, we have the following equation for volume:

$$\begin{aligned}V &= \pi r^2 h \\ 14.4375 &= \pi r^2 h \\ \frac{14.4375}{\pi} &= r^2 h \\ 4.5956 &= r^2 h\end{aligned}$$

The last equation gives us a relation between the radius and height of the cylinder that must be fulfilled to get the desired volume. First, choose a suitable radius, say 1.85 in, and solve for the height.

12-4 Volumes of Prisms and Cylinders

$$4.5956 = r^2 h$$

$$4.5956 = (1.85)^2 h$$

$$h = 4.5956 / (1.85)^2$$

$$h \approx 1.34$$

If we choose a height of say 4 in., then we can solve for the radius.

$$V = \pi r^2 h$$

$$4.5956 = r^2 h$$

$$4.5956 = r^2 (4)$$

$$\frac{4.5956}{4} = r^2$$

$$1.1489 = r^2$$

$$r = \sqrt{1.1489}$$

$$r \approx 1.07$$

For any rectangular container, the volume equation is:

$$V = l \cdot w \cdot h$$

$$14.4375 = l \cdot w \cdot h$$

Choose numbers for any two of the dimensions and we can solve for the third. Let $l = 2.25$ in. and $w = 2.5$ in.

$$14.4375 = l \cdot w \cdot h$$

$$14.4375 = (2.25)(2.5)h$$

$$14.4375 = 5.625h$$

$$h = 14.4375 / 5.625$$

$$h \approx 2.6$$

12-4 Volumes of Prisms and Cylinders

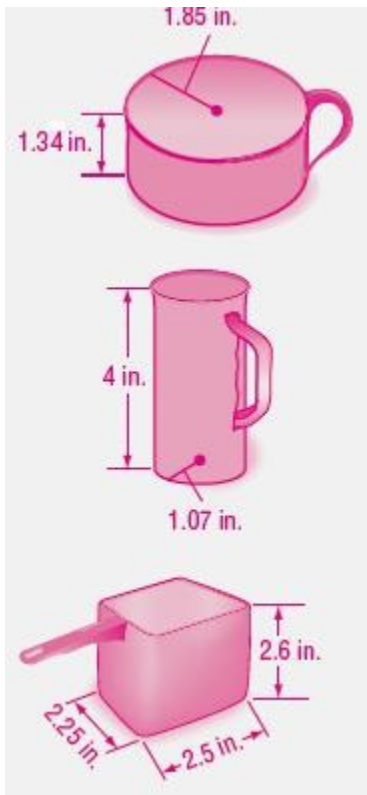

ANSWER:

Sample answers:

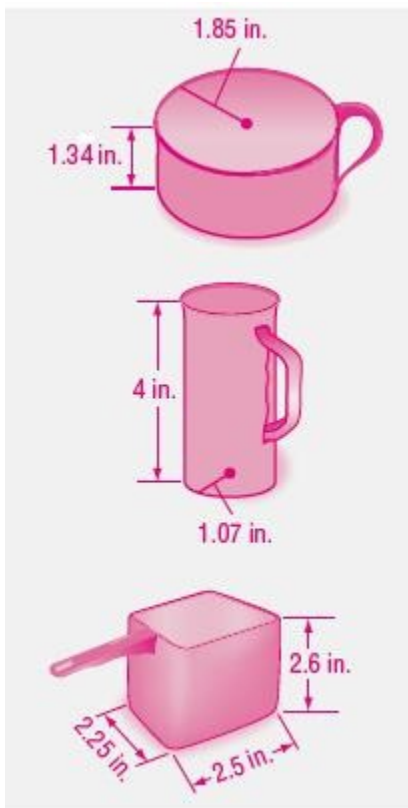

12-4 Volumes of Prisms and Cylinders

39. Find the volume of the regular pentagonal prism by dividing it into five equal triangular prisms. Describe the base area and height of each triangular prism.

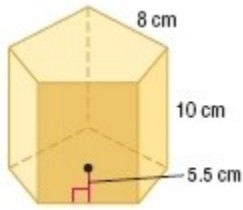

SOLUTION:

The base of the prism can be divided into 5 congruent triangles of a base 8 cm and the corresponding height 5.5 cm. So, the pentagonal prism is a combination of 5 triangular prisms of height 10 cm. Find the base area of each triangular prism.

$$\frac{1}{2}(8)(5.5) = 22 \text{ cm}^2$$

Therefore, the volume of the pentagonal prism is $5(22)(10) = 1110 \text{ cm}^3$.

ANSWER:

1100 cm^3 ; Each triangular prism has a base area of $\frac{1}{2}(8)(5.5)$ or 22 cm^2 and a height of 10 cm.

40. **PATIOS** Mr. Thomas is planning to remove an old patio and install a new rectangular concrete patio 20 feet long, 12 feet wide, and 4 inches thick. One contractor bid \$2225 for the project. A second contractor bid \$500 per cubic yard for the new patio and \$700 for removal of the old patio. Which is the less expensive option? Explain.

SOLUTION:

Convert all of the dimensions to yards.

$$20 \text{ feet} = \frac{20}{3} \text{ yd}$$

$$12 \text{ feet} = 4 \text{ yd}$$

$$4 \text{ in.} = \frac{4}{36} = \frac{1}{9} \text{ yd}$$

Find the volume.

$$\begin{aligned} V &= Bh \\ &= \left(\frac{20}{3}\right)\left(4\right)\left(\frac{1}{9}\right) \\ &= \frac{80}{27} \\ &\approx 2.96 \end{aligned}$$

The total cost for the second contractor is about $2.96(500) + 700 = 2181.5$.

Therefore, the second contractor is a less expensive option.

ANSWER:

Because 2.96 yd^3 of concrete are needed, the second contractor is less expensive at \$2181.50.

12-4 Volumes of Prisms and Cylinders

41. **MULTIPLE REPRESENTATIONS** In this problem, you will investigate right and oblique cylinders

a. GEOMETRIC Draw a right cylinder and an oblique cylinder with a height of 10 meters and a diameter of 6 meters.

b. VERBAL A square prism has a height of 10 meters and a base edge of 6 meters. Is its volume *greater than*, *less than*, or *equal to* the volume of the cylinder? Explain.

c. ANALYTICAL Describe which change affects the volume of the cylinder more: multiplying the height by x or multiplying the radius by x . Explain.

SOLUTION:

a. The oblique cylinder should look like the right cylinder (same height and size), except that it is pushed a little to the side, like a slinky.

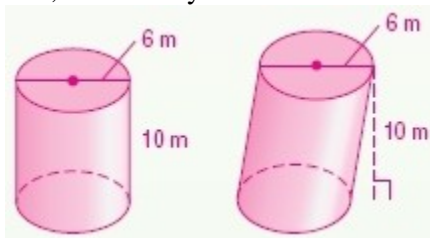

b. Find the volume of each.

$$\begin{aligned}V(\text{cylinder}) &= Bh \\&= \pi r^2 \cdot h \\&= \pi(3)^2(10) \\&\approx 282.7\end{aligned}$$

$$\begin{aligned}V(\text{prism}) &= Bh \\&= 6^2 \cdot 10 \\&= 360\end{aligned}$$

The volume of the square prism is greater.

c. Do each scenario.

$$\begin{aligned}V &= Bh \\&= \pi r^2 \cdot h \\&= \pi(3)^2(10x) \\&\approx 282.7x\end{aligned}$$

$$\begin{aligned}V &= Bh \\&= \pi r^2 \cdot h \\&= \pi(3x)^2(10) \\&\approx 282.7x^2\end{aligned}$$

Assuming $x > 1$, multiplying the radius by x makes the volume x^2 times greater.

12-4 Volumes of Prisms and Cylinders

For example, if $x = 0.5$, then $x^2 = 0.25$, which is less than x .

ANSWER:

a.

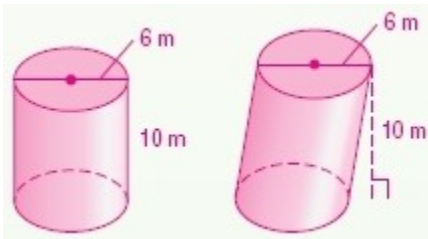

b. Greater than; a square with a side length of 6 m has an area of 36 m^2 . A circle with a diameter of 6 m has an area of 9π or 28.3 m^2 . Since the heights are the same, the volume of the square prism is greater.

c. Multiplying the radius by x ; since the volume is represented by $\pi r^2 h$, multiplying the height by x makes the volume x times greater. Multiplying the radius by x makes the volume x^2 times greater, assuming $x > 1$.

42. **CCSS CRITIQUE** Franciso and Valerie each calculated the volume of an equilateral triangular prism with an apothem of 4 units and height of 5 units. Is either of them correct? Explain your reasoning.

$$\begin{aligned} \text{Francisco} \\ V &= Bh \\ &= \frac{1}{2} aP \cdot h \\ &= \frac{1}{2} (4)(24\sqrt{3}) \cdot 5 \\ &= 240\sqrt{3} \text{ cubic units} \end{aligned}$$

$$\begin{aligned} \text{Valerie} \\ V &= Bh \\ &= \frac{\sqrt{3}}{2} s^2 \cdot h \\ &= \frac{\sqrt{3}}{2} (4\sqrt{3})^2 \cdot 5 \\ &= 120\sqrt{3} \text{ cubic units} \end{aligned}$$

SOLUTION:

Franciso; Valerie incorrectly used $4\sqrt{3}$ as the length of one side of the triangular base. Franciso used a different approach, but his solution is correct.

Franciso used the standard formula for the volume of a solid, $V = Bh$. The area of the base, B , is one-half the apothem multiplied by the perimeter of the base.

ANSWER:

Franciso; Valerie incorrectly used $4\sqrt{3}$ as the length of one side of the triangular base. Franciso used a different approach, but his solution is correct.

43. **CHALLENGE** A cylindrical can is used to fill a container with liquid. It takes three full cans to fill the container. Describe possible dimensions of the container if it is each of the following shapes.

a. rectangular prism

b. square prism

12-4 Volumes of Prisms and Cylinders

- c. triangular prism with a right triangle as the base

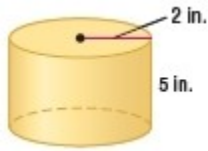

SOLUTION:

The volume of the can is $20\pi \text{ in}^3$. It takes three full cans to fill the container, so the volume of the container is $60\pi \text{ in}^3$.

- a. Choose some basic values for 2 of the sides, and then determine the third side. Base: 3 by 5.

$$V = Bh$$

$$60\pi = (3)(5) \cdot h$$

$$60\pi = 15h$$

$$4\pi = h$$

3 by 5 by 4π

- b. Choose some basic values for 2 of the sides, and then determine the third side. Base: 5 by 5.

$$V = Bh$$

$$60\pi = (5)(5) \cdot h$$

$$60\pi = 25h$$

$$\frac{60}{25}\pi = h$$

$$\frac{12}{5}\pi = h$$

5 by 5 by $\frac{12}{5}\pi$

- c. Choose some basic values for 2 of the sides, and then determine the third side. Base: Legs: 3 by 4.

$$V = Bh$$

$$60\pi = \frac{1}{2}(3)(4) \cdot h$$

$$60\pi = 6h$$

$$\frac{60}{6}\pi = h$$

$$10\pi = h$$

3 by 4 by 10π

ANSWER:

Sample answers:

- a. 3 by 5 by 4π

12-4 Volumes of Prisms and Cylinders

b. 5 by 5 by $\frac{12}{5}\pi$

c. base with legs measuring 3 in. and 4 in., height 10π in.

44. **WRITING IN MATH** Write a helpful response to the following question posted on an Internet gardening forum.

I am new to gardening. The nursery will deliver a truckload of soil, which they say is 4 yards. I know that a yard is 3 feet, but what is a yard of soil? How do I know what to order?

SOLUTION:

Sample answer: The nursery means a cubic yard, which is 3^3 or 27 cubic feet. Find the volume of your garden in cubic feet and divide by 27 to determine the number of cubic yards of soil needed.

ANSWER:

Sample answer: The nursery means a cubic yard, which is 3^3 or 27 cubic feet. Find the volume of your garden in cubic feet and divide by 27 to determine the number of cubic yards of soil needed.

45. **OPEN ENDED** Draw and label a prism that has a volume of 50 cubic centimeters.

SOLUTION:

Choose 3 values that multiply to make 50. The factors of 50 are 2, 5, 5, so these are the simplest values to choose.

Sample answer:

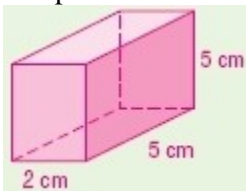

ANSWER:

Sample answer:

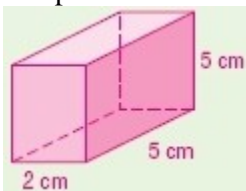

12-4 Volumes of Prisms and Cylinders

46. **REASONING** Determine whether the following statement is *true* or *false*. Explain.
Two cylinders with the same height and the same lateral area must have the same volume.

SOLUTION:

True; if two cylinders have the same height ($h_1 = h_2$) and the same lateral area ($L_1 = L_2$), the circular bases must have the same area.

$$L_1 = L_2$$

$$2\pi r_1 h_1 = 2\pi r_2 h_2$$

$$h_1 = h_2$$

$$2\pi r_1 = 2\pi r_2$$

$$r_1 = r_2$$

The radii must also be equal.

ANSWER:

True; if two cylinders have the same height and the same lateral area, the circular bases must have the same area. Therefore, $\pi r^2 h$ is the same for each cylinder.

47. **WRITING IN MATH** How are the formulas for the volume of a prism and the volume of a cylinder similar? How are they different?

SOLUTION:

Both formulas involve multiplying the area of the base by the height. The base of a prism is a polygon, so the expression representing the area varies, depending on the type of polygon it is. The base of a cylinder is a circle, so its area is πr^2 .

ANSWER:

Sample answer: Both formulas involve multiplying the area of the base by the height. The base of a prism is a polygon, so the expression representing the area varies, depending on the type of polygon it is. The base of a cylinder is a circle, so its area is πr^2 .

12-4 Volumes of Prisms and Cylinders

48. The volume of a triangular prism is 1380 cubic centimeters. Its base is a right triangle with legs measuring 8 centimeters and 15 centimeters. What is the height of the prism?

- A 34.5 cm
B 23 cm
C 17 cm
D 11.5 cm

SOLUTION:

$$V = Bh$$

$$1380 = \frac{1}{2}(8)(15) \cdot h$$

$$1380 = 60h$$

$$\frac{1380}{60} = h$$

$$23 = h$$

ANSWER:

B

49. A cylindrical tank used for oil storage has a height that is half the length of its radius. If the volume of the tank is 1,122,360 ft³, what is the tank's radius?

- F 89.4 ft
G 178.8 ft
H 280.9 ft
J 561.8 ft

SOLUTION:

$$V = Bh$$

$$1,122,360 = \pi r^2 \cdot h$$

$$1,122,360 = \pi(2h)^2 \cdot h$$

$$1,122,360 = 4\pi h^3$$

$$\frac{1,122,360}{4\pi} = h^3$$

$$\sqrt[3]{\frac{1,122,360}{4\pi}} = h$$

$$44.7 \approx h$$

ANSWER:

F

12-4 Volumes of Prisms and Cylinders

50. **SHORT RESPONSE** What is the ratio of the area of the circle to the area of the square?

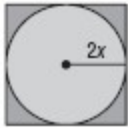

SOLUTION:

The radius of the circle is $2x$ and the length of each side of the square is $4x$. So, the ratio of the areas can be written as shown.

$$\frac{\text{Area of the circle}}{\text{Area of the square}} = \frac{\pi(2x)^2}{(4x)^2} = \frac{4\pi x^2}{16x^2} = \frac{\pi}{4}$$

ANSWER:

$$\frac{\pi}{4}$$

51. **SAT/ACT** A county proposes to enact a new 0.5% property tax. What would be the additional tax amount for a landowner whose property has a taxable value of \$85,000?
- A \$4.25
B \$170
C \$425
D \$4250
E \$42,500

SOLUTION:

Find the 0.5% of \$85,000.

$$\frac{0.5}{100}(85000) = 425$$

Therefore, the correct choice is C.

ANSWER:

C

Find the lateral area and surface area of each regular pyramid. Round to the nearest tenth if necessary.

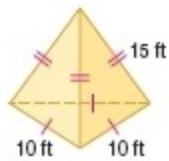

52.

SOLUTION:

The lateral area L of a regular pyramid is $L = \frac{1}{2}P\ell$, where ℓ is the slant height and P is the perimeter of the base.

The slant height is the height of each of the congruent lateral triangular faces. Use the Pythagorean Theorem to find the slant height.

12-4 Volumes of Prisms and Cylinders

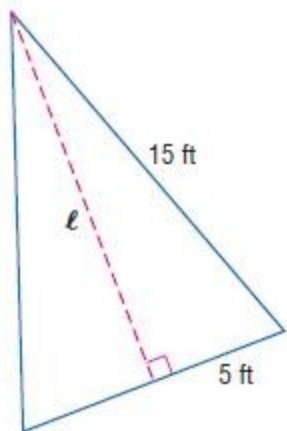

$$l^2 + 5^2 = 15^2$$

$$l^2 = 225 - 25$$

$$l = \sqrt{200} \text{ or } 10\sqrt{2}$$

Find the perimeter and area of the equilateral triangle for the base. Use the Pythagorean Theorem to find the height h of the triangle.

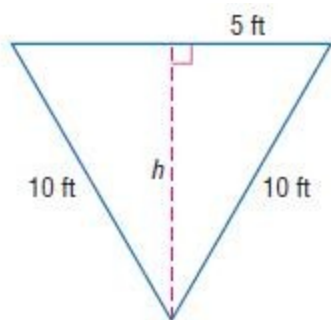

$$h^2 + 5^2 = 10^2$$

$$h^2 = 100 - 25$$

$$h = \sqrt{75} \text{ or } 5\sqrt{3}$$

The perimeter is $P = 3 \times 10$ or 30 feet.

$$A = \frac{1}{2}bh$$

$$= \frac{1}{2}(10)(5\sqrt{3})$$

$$= 25\sqrt{3}$$

So, the area of the base B is $25\sqrt{3} \text{ ft}^2$.

12-4 Volumes of Prisms and Cylinders

Find the lateral area L and surface area S of the regular pyramid.

$$\begin{aligned}L &= \frac{1}{2}P\ell \\ &= \frac{1}{2}(30)(10\sqrt{2}) \\ &\approx 212.1\end{aligned}$$

So, the lateral area of the pyramid is about 212.1 ft^2 .

$$\begin{aligned}S &= \frac{1}{2}P\ell + B \\ &= \frac{1}{2}(30)(10\sqrt{2}) + 25\sqrt{3} \\ &= 150\sqrt{2} + 25\sqrt{3} \\ &\approx 255.4\end{aligned}$$

Therefore, the surface area of the pyramid is about 255.4 ft^2 .

ANSWER:

212.1 ft^2 ; 255.4 ft^2

12-4 Volumes of Prisms and Cylinders

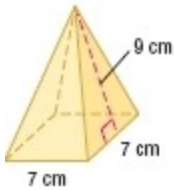

53.

SOLUTION:

The lateral area L of a regular pyramid is $L = \frac{1}{2}P\ell$, where ℓ is the slant height and P is the perimeter of the base.

Here, the base is a square of side 7 cm and the slant height is 9 cm.

$$\begin{aligned}L &= \frac{1}{2}P\ell \\ &= \frac{1}{2}(4 \times 7)(9) \\ &= 126\end{aligned}$$

So, the lateral area of the pyramid is 126 cm^2 .

The surface area S of a regular pyramid is $S = L + B$, where L is the lateral area and B is the area of the base.

$$\begin{aligned}S &= \frac{1}{2}P\ell + s^2 \\ &= \frac{1}{2}(4 \times 7)(9) + (7)^2 \\ &= 126 + 49 \\ &= 175\end{aligned}$$

Therefore, the surface area of the pyramid is 175 cm^2 .

ANSWER:

$$126 \text{ cm}^2; 175 \text{ cm}^2$$

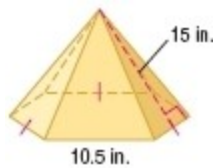

54.

SOLUTION:

The pyramid has a slant height of 15 inches and the base is a hexagon with sides of 10.5 inches.

A central angle of the hexagon is $\frac{360^\circ}{6}$ or 60° , so the angle formed in the triangle below is 30° .

12-4 Volumes of Prisms and Cylinders

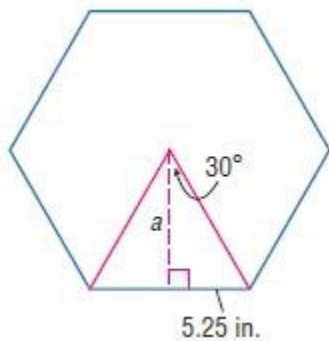

Use a trigonometric ratio to find the measure of the apothem a .

$$\begin{aligned}\tan 30 &= \frac{5.25}{a} \\ a \tan 30 &= 5.25 \\ a &= \frac{5.25}{\tan 30}\end{aligned}$$

Find the lateral area and surface area of the pyramid.

$$\begin{aligned}L &= \frac{1}{2}P\ell \\ &= \frac{1}{2}(6 \times 10.5)(15) \\ &= 472.5\end{aligned}$$

So, the lateral area of the pyramid is 472.5 in^2 .

$$\begin{aligned}S &= \frac{1}{2}P\ell + B \\ &= \frac{1}{2}P\ell + \frac{1}{2}aP \\ &= \frac{1}{2}(6 \times 10.5)(15) + \frac{1}{2}\left(\frac{5.25}{\tan 30}\right)(6 \times 10.5) \\ &\approx 472.5 + 286.4 \\ &\approx 758.9\end{aligned}$$

Therefore, the surface area of the pyramid is about 758.9 in^2 .

ANSWER:

$$472.5 \text{ in}^2; 758.9 \text{ in}^2$$

12-4 Volumes of Prisms and Cylinders

55. **BAKING** Many baking pans are given a special nonstick coating. A rectangular cake pan is 9 inches by 13 inches by 2 inches deep. What is the area of the inside of the pan that needs to be coated?



SOLUTION:

The area that needs to be coated is the sum of the lateral area and one base area.

Therefore, the area that needs to be coated is $2(13 + 9)(2) + 13(9) = 205 \text{ in}^2$.

ANSWER:

205 in^2

Find the indicated measure. Round to the nearest tenth.

56. The area of a circle is 54 square meters. Find the diameter.

SOLUTION:

$$A = \pi r^2$$

$$54 = \pi r^2$$

$$\frac{54}{\pi} = r^2$$

$$\sqrt{\frac{54}{\pi}} = r$$

$$4.14 = r$$

The diameter of the circle is about 8.3 m.

ANSWER:

8.3 m

57. Find the diameter of a circle with an area of 102 square centimeters.

SOLUTION:

$$A = \pi r^2$$

$$102 = \pi r^2$$

$$\frac{102}{\pi} = r^2$$

$$\sqrt{\frac{102}{\pi}} = r$$

$$5.7 = r$$

The diameter of the circle is about 11.4 m.

ANSWER:

11.4 cm

12-4 Volumes of Prisms and Cylinders

58. The area of a circle is 191 square feet. Find the radius.

SOLUTION:

$$A = \pi r^2$$

$$191 = \pi r^2$$

$$\frac{191}{\pi} = r^2$$

$$\sqrt{\frac{191}{\pi}} = r$$

$$7.8 = r$$

ANSWER:

7.8 ft

59. Find the radius of a circle with an area of 271 square inches.

SOLUTION:

$$A = \pi r^2$$

$$271 = \pi r^2$$

$$\frac{271}{\pi} = r^2$$

$$\sqrt{\frac{271}{\pi}} = r$$

$$9.3 = r$$

ANSWER:

9.3 in.

12-4 Volumes of Prisms and Cylinders

Find the area of each trapezoid, rhombus, or kite.

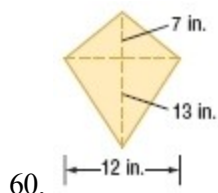

SOLUTION:

The area A of a kite is one half the product of the lengths of its diagonals, d_1 and d_2 .

$$d_1 = 12 \text{ in. and } d_2 = 7 + 13 = 20 \text{ in.}$$

$$\begin{aligned} A &= \frac{1}{2}d_1d_2 \\ &= \frac{1}{2}(12)(20) \\ &= 120 \end{aligned}$$

ANSWER:

$$120 \text{ in}^2$$

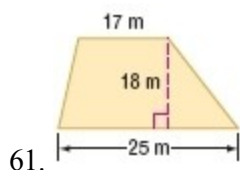

SOLUTION:

The area A of a trapezoid is one half the product of the height h and the sum of the lengths of its bases, b_1 and b_2 .

$$\begin{aligned} A &= \frac{1}{2}(b_1 + b_2)h \\ &= \frac{1}{2}(17 + 25)18 \\ &= 378 \end{aligned}$$

ANSWER:

$$378 \text{ m}^2$$

12-4 Volumes of Prisms and Cylinders

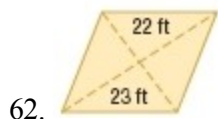

SOLUTION:

$$d_1 = 2(22) = 44 \text{ and } d_2 = 2(23) = 46$$

$$\begin{aligned} A &= \frac{1}{2}d_1d_2 \\ &= \frac{1}{2}(44)(46) \\ &= 1012 \end{aligned}$$

ANSWER:

$$1012 \text{ ft}^2$$